

TITAN-X Series

TITAN-X SERIES

THE ULTIMATE TRANSPARENT TOURING SOLUTION

VUEPIX
INFILED

TITAN-X Series

The Ultimate Transparent Touring Solutions

The VuePix Infiled TITAN-X series is a new ultimate rental LED system specifically designed for outdoor touring markets.

The new cutting edge TITAN-X outdoor touring panels feature high-brightness LEDs of 8.3mm pixel pitch, producing stunning visuals with vibrant colours and high contrast. Each LED diode has been treated with an advanced protection shield, providing the ultimate UV, weather & dust protection.

The unique design of the TITAN-X cabinets offers an excellent transparency of 70%, bringing new dimensions to your creative outdoor stage sets and allowing the sound and light effects to easily cut through the LED wall system.

The panels are remarkably strong and robust, but also extremely lightweight. Each cabinet offers extensive load capacity and advanced overall stability due to its innovative X-frame structure – a unique rear triangular foldable wind bracing system. The large-format TITAN-X video walls can resist wind speeds of up to 20m/sec, with the screen reaching a height of up to 24m, making these panels a perfect choice for outdoor festivals and events.

The extra-large size cabinets (1200x1200mm) feature an intuitive lock in system, resulting in a rapid installation. The TITAN-X frame is climbable and allows for both front or rear service and easy maintenance access.

A dedicated dolly system has been specifically developed to allow for easy transportation and to make the installation process super-efficient. The innovative design of the panels enables lifting operation straight from the dolly. The foldable bracing design of each cabinet saves on storage space, the cabinets can be transported in their dollies even with extra accessories being attached.

Designed to provide you with infinite creative possibilities for your stage, the TITAN-X video wall can be set up as a convex or concave curved display of the ± 15 deg angle.



IP65



High
Brightness

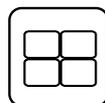

Modular
Design



Easy
Maintenance

High Performance Panels

The TITAN-X outdoor touring panels feature high-brightness LEDs of 8.3mm pixel pitch, producing stunning visuals with vibrant colours and high contrast.

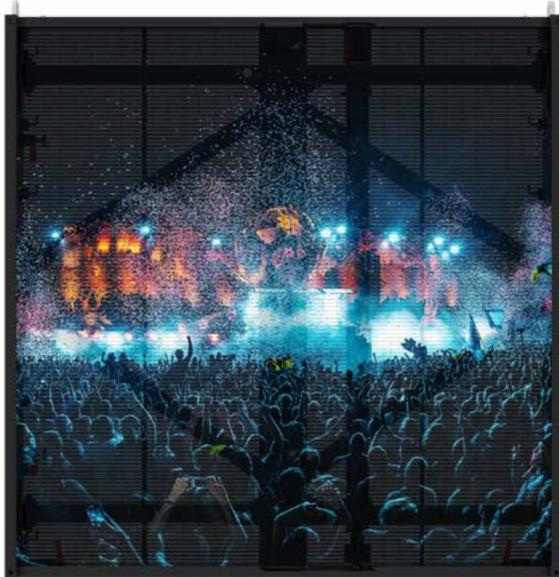

Excellent Transparency

The unique design of the TITAN-X cabinets offers an excellent transparency of 70%, bringing new dimensions to your creative outdoor stage sets and allowing the sound and light effects to easily cut through the LED wall system.

70% Transparency

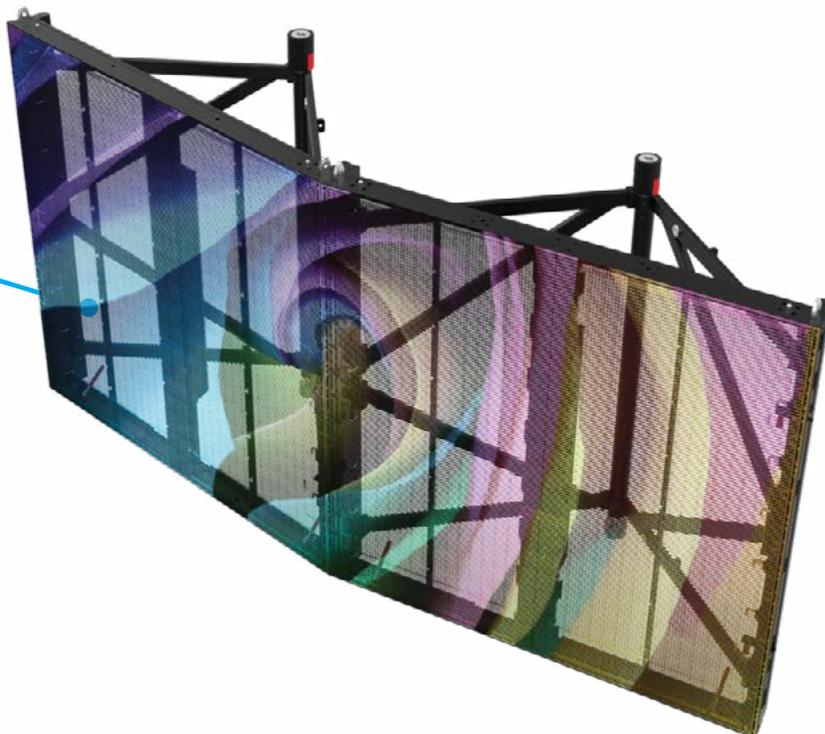

Remarkably Strong yet Lightweight

The panels are remarkably strong and robust, but also extremely lightweight, with a weight of only 22kg/sqm.

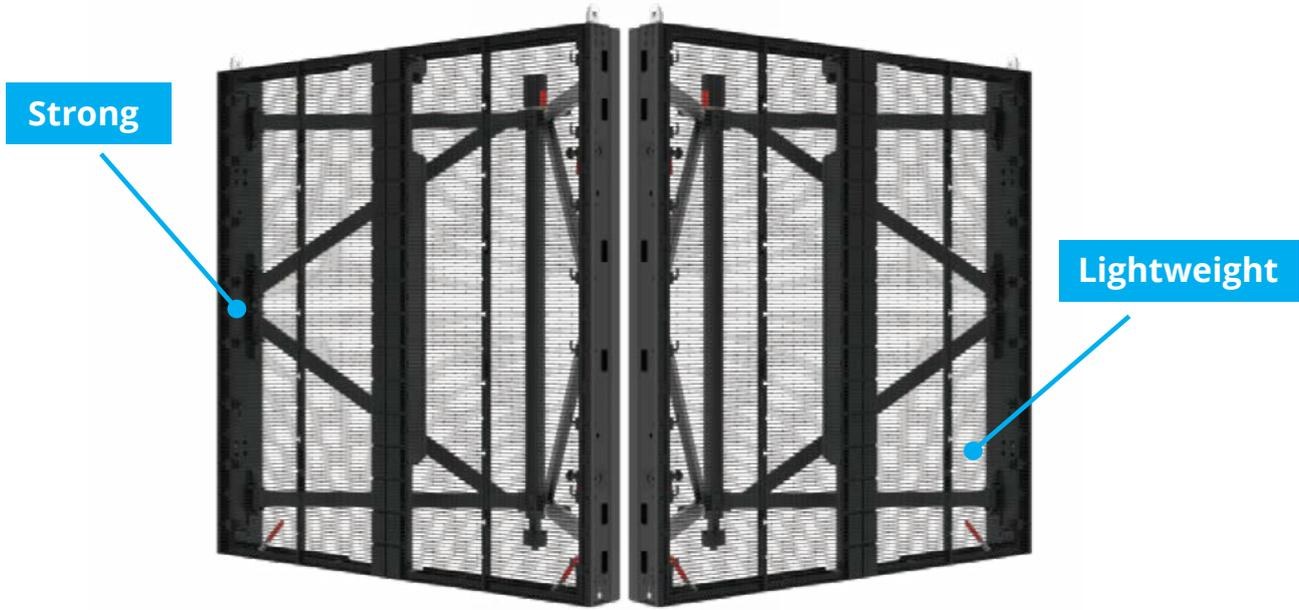

Extra Protection

Each LED diode has been treated with an advanced protection shield, providing the ultimate UV, weather & dust protection.



UV
Protection



Water
Protection

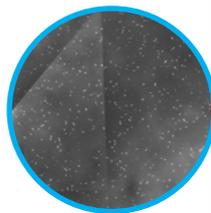

Dust
Protection

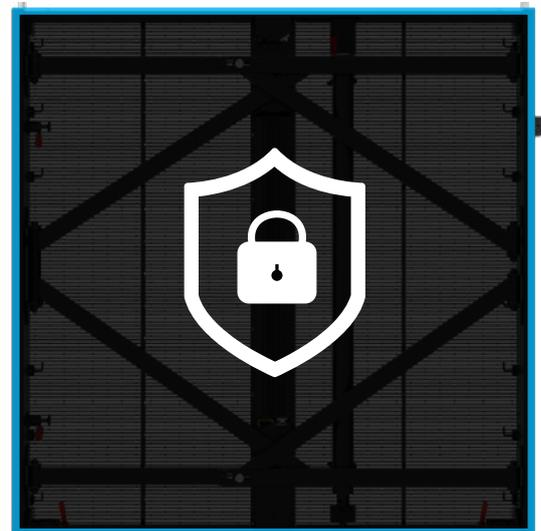

Innovative Frame Structure

Each cabinet offers extensive load capacity and advanced overall stability due to its innovative X-frame structure – a unique rear triangular foldable wind bracing system.

The large-format TITAN-X video walls can resist wind speeds of up to 20m/sec, with the screen reaching a height of up to 24m, making these panels a perfect choice for outdoor festivals and events.

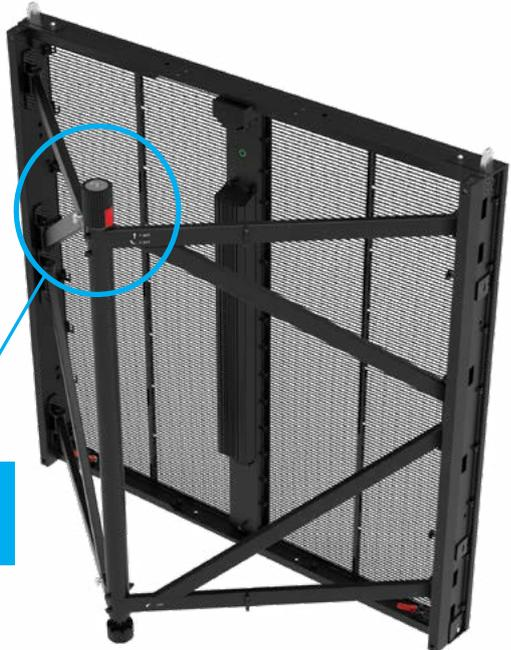

**Triangular foldable
wind bracing system**

Curved Displays

Designed to provide you with infinite creative possibilities for your stage, the TITAN-X video wall can be set up as a convex or concave curved display of the $\pm 15^\circ$ angle.

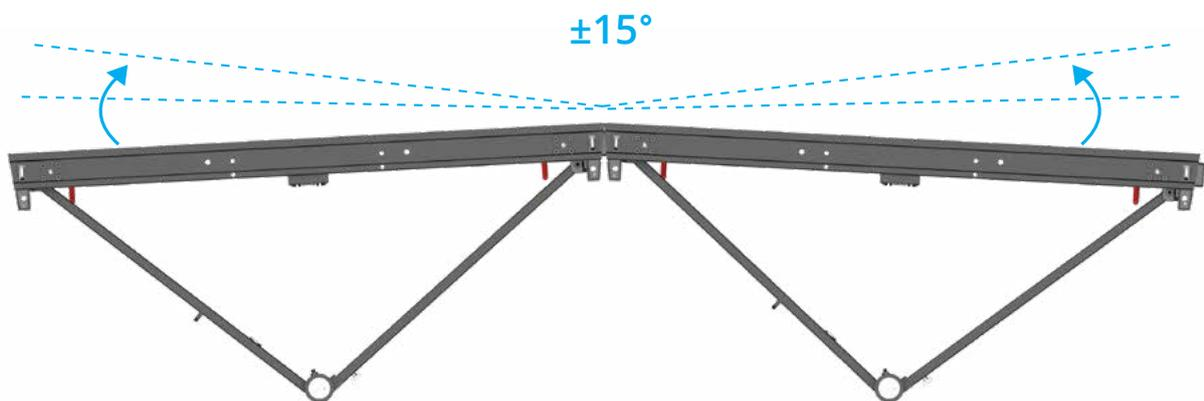



Unique Dolly System

A dedicated dolly system has been specifically developed to allow for easy transportation and to make the installation process super-efficient. The innovative design of the panels enables lifting operation straight from the dolly. The foldable bracing design of each cabinet saves on storage space, the cabinets can be transported in their dollies even with extra accessories being attached.



Efficient Installation

The extra-large size cabinets (1200x1200mm) feature an intuitive lock in system, resulting in a rapid installation.

Specifications

TITAN-X8	
Series	TITAN-X
Pixel Pitch	8.3mm
Environment	Outdoor
LED Configuration	3 IN 1 SMD
Max. Brightness	4,000 nits
Refresh Rate	≤3,840 Hz
Viewing Angle	160°/160°
Cabinet Resolution	144 x 144 pixels
Cabinet Width	1200 mm
Cabinet Height	1200 mm
Cabinet Depth	116 mm
Cabinet Weight	30 kg
Max. Power Consumption	460 W /m ² , 660 W /panel
Aver. Power Consumption	150 W /m ² , 220 W /panel
Transparency	70%
Curving	±15°
Operating Power Source	100-240V AC, 50-60Hz
Operating Temperature	-20°C~+45°C
Ingress Protection	IP65
Verification	DP, HDMI, DVI, VGA, SDI
Application	Rental



LEADERS IN LED SCREENS & DIGITAL DISPLAYS

info@vuepix.tv | www.vuepix.tv

Australia: 1800 883 749 New Zealand: 09 218 6532 International: +61 7 5509 4633